



VORTEX FLOWMETER
User Manual
(V 4.1)

AFM-10 / Swirl Flowmeter

User Manual

1	OVERVIEW.....	1
1.1	TECHNICAL SUPPORT	1
1.2	MAIN SPECIFICATION	1
1.3	FEATURES	1
2	HARDWARE.....	2
2.1	TERMINAL BOARD WIRING.....	2
2.1.1	4~20MA OUTPUT+ HART+ EXTERNAL PRESSURE.....	2
2.1.2	PULSE OUTPUT+ EXTERNAL PRESSURE AND TEMPERATURE SENSORS.....	2
2.2	SENSOR INTERFACE.....	3
2.2.1	VORTEX SENSOR	3
2.2.2	PRESSURE SENSOR	3
2.2.3	TEMPERATURE SENSOR.....	3
3	LCD DISPLAY	4
3.1	THREE-LINE DISPLAY MODE	4
3.2	TWO-LINE DISPLAY MODE	4
4	PRODUCTION PROCESS USING HART-CONFIG TOOL.....	5
5	PRODUCTION PROCESS VIA LOCAL ADJUSTMENT.....	6
6	DATA ENTRY	7
6.1	BASIC FUNCTION OF KEYS	7
6.2	ENTER OR EXIT MENU MODE.....	7
6.2.1	ENTER MENU MODE	7
6.2.2	EXIT MENU MODE	7
6.3	DATA ENTRY METHOD.....	7
6.3.1	SELECT METHOD	7
6.3.2	DATA INPUT METHOD.....	7
6.4	LOCAL CONFIGURATION FUNCTION	8
6.4.1	BASIC FUNCTION (NO PASSWORD).....	8
6.4.2	ADVANCED FUNCTION (PASSWORD PROTECTION).....	9
6.5	TOTALIZER FLOW UNIT TABLE	13
7	PARAMETER DESCRIPTION.....	13
7.1	K- FACTOR	13

7.2	FIVE-POINT LINEARITY CORRECTION	13
7.3	PULSE FACTOR DESCRIPTION	14
7.4	OUTPUT ORIGINAL PULSES DESCRIPTION.....	14
7.5	TEMPERATURE AND PRESSURE COMPENSATION	14
7.5.1	PRECONDITION.....	14
7.5.2	PRESSURE SENSOR TRIM.....	14
7.5.3	LOW PRESSURE CUTOFF VALUE.....	15
7.5.4	PRESSURE BIAS SETTINGS.....	15
7.5.5	TEMPERATURE SENSOR TRIM.....	15
7.6	MEASUREMENT MODE SETUP INSTRUCTIONS.....	16
7.6.1	GAS QV.....	16
7.6.2	GAS QM.....	16
7.6.3	LIQUID QV	16
7.6.4	LIQUID QM	16
7.6.5	STEAM QV	16
7.6.6	STEAM MASS	17
7.6.7	LANGUAGE OPTION.....	17

AFM-10 / Vortex Flowmeter

User Manual

1 Overview

1.1 Technical Support

AFM-10 is designed for HART vortex/Vortex flowmeters with pressure and temperature compensation function.

Please read this manual carefully before use AFM-10 Please follow this manual to complete your operation. If you have any questions, please do not hesitate to contact us.

1.2 Main Specification

Power supply:	12-32VDC
Operating temperature:	-20°C ~ +70°C(with LCD) -40°C ~ +85°C(without LCD)

1.3 Features

- Output:** 4~20mA output with HART
- Configuration:** Flow mode, Flow unit, Range (Qmax), Density, Display, etc.
- Alarm:** Low alarm will output 3.8mA, high alarm will output 22.0mA.
- K-Factor linearity:** AFM-10 provides 2 to 5 points k-Factor correction.
- Local adjust functions:** Setting flow range and unit, Density, Flow mode, damping, alarm, and data recovery etc.
- LCD display:** The first line shows the instantaneous flow. The second line shows the totalized flow. The third line can display the percentage, loop current, temperature, pressure, density and so on.
- Perfect compensation:** AFM-10 supports real-time temperature and pressure compensation for gas, supports the international standard of steam density table, temperature and pressure compensation for over heat steam, pressure compensation or temperature compensation for saturated steam.
- Restore factory settings:** If the damping value entered is '05678', it will automatically perform 'restore factory settings'. (Manufacturers need to perform 'Data Backup' operation.)
- Temperature trim:** High trim and low trim easily.
- Pressure trim:** High trim and low trim easily.
- AFM-10 has a power-down data protection function and a flow accumulation function.



2 Hardware

2.1 Terminal Board Wiring

The terminal board is used for connects the external power supply, output pulse, the external pressure sensor and temperature sensor.

The following are common wiring.

2.1.1 4~20mA output+ HART+ External Pressure

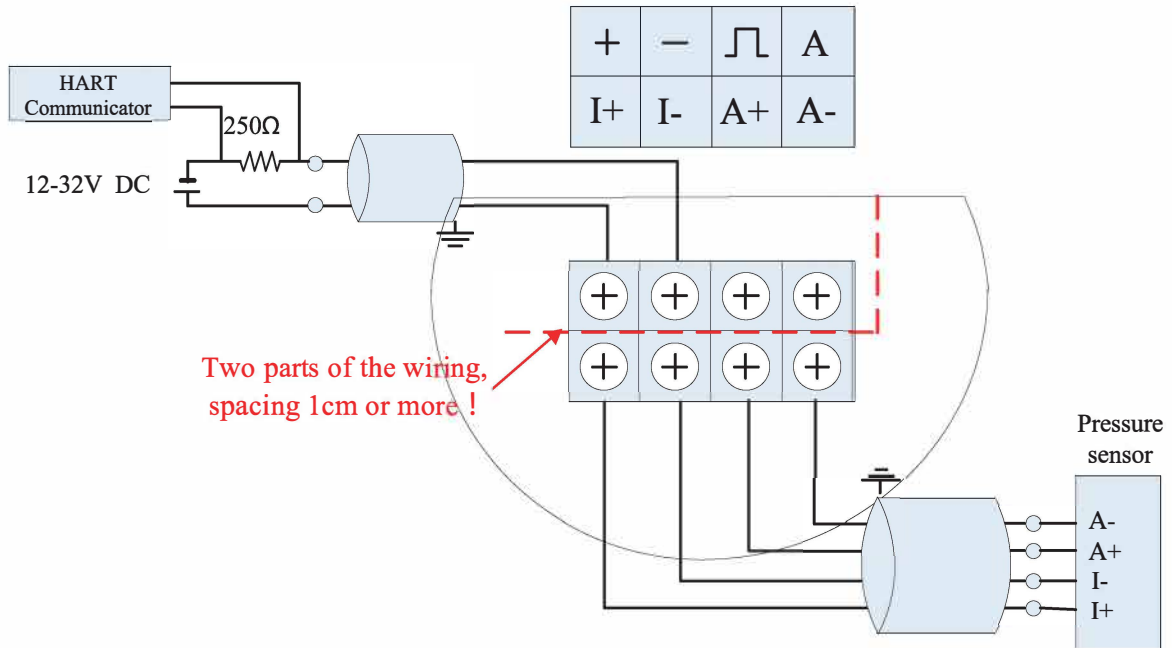

2.1.2 Pulse Output+ External Pressure and Temperature sensors

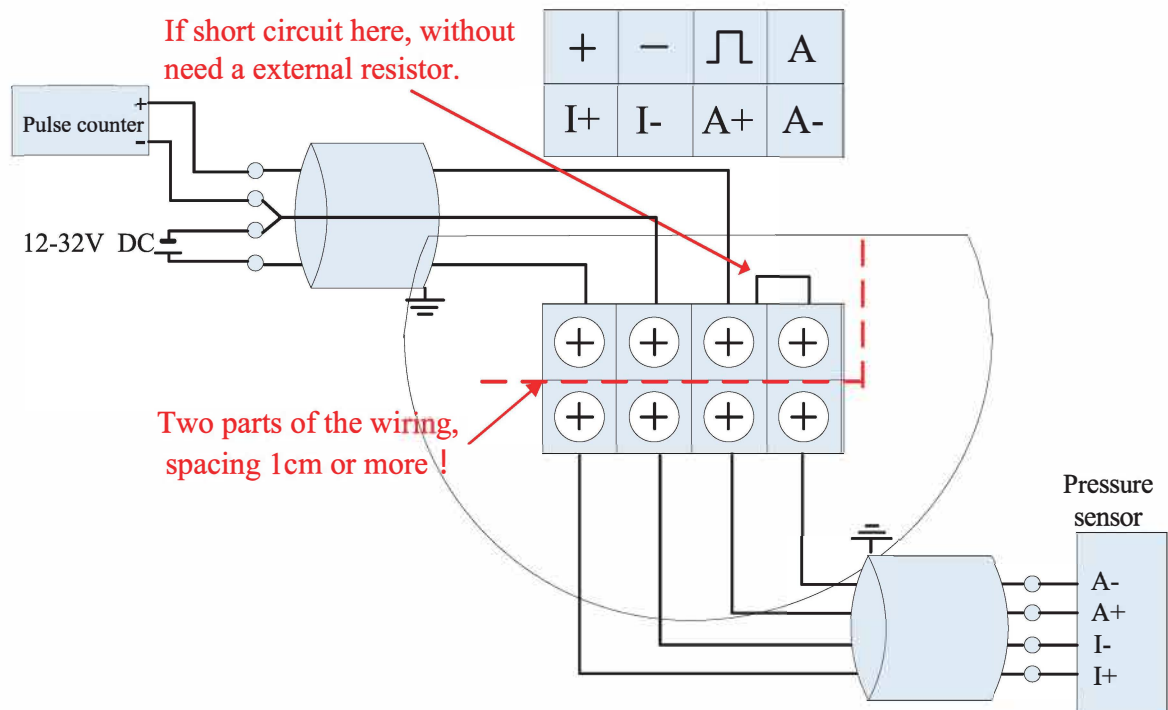

2.2 Sensor Interface

2.2.1 Vortex Sensor

The 2-Pin green terminal XT is used for connecting the vortex sensor.



2.2.2 Pressure Sensor

Users can use XF3 socket to connect pressure sensor, and the pressure sensor should be bridge type sensors. I+ and I- are power supply, A+ and A- are the sensor signal outputs.

The bridge impedance of the pressure sensor is required to be between 3000 and 6000 ohms. The excitation current of the sensor is about 0.3mA, and the output of the sensor is required to not exceed 50mV@0.3mA.

Socket XF3 defined as follows:

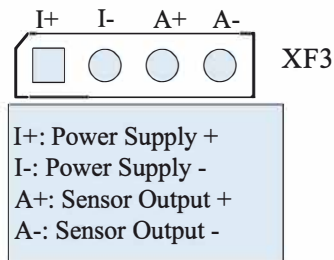

2.2.3 Temperature Sensor

Socket XF5 supports Pt1000 and Pt100, two-wire connection.

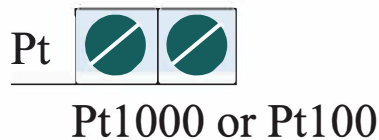

Installation Notes: To ensure reliable grounding, the board must be securely attached to the housing for testing!

3 LCD Display

LCD with 128 * 64 dot matrix display, support for multi-variable display.

The instrument supports two display modes :

3.1 Three-line display mode

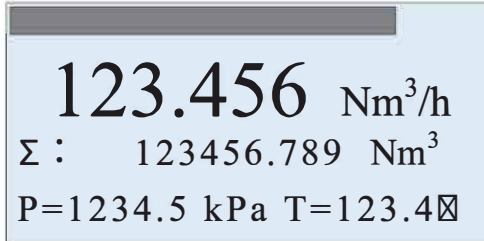

Displays the current percentage in progress bar

First line display Instantaneous flow.

The second line display totalized flow.

The third line display frequency, pressure, temperature, density, current or the percentage.

Notes:

- ☒ If enable automatic measure pressure, and the pressure signal abnormality (sensor fault), the corresponding pressure value will be replaced with the set pressure value and will flash.
- ☒ If enable automatic measure temperature, and the temperature signal abnormality (sensor fault), the corresponding temperature value will be replaced with the set temperature value and will flash.
- ☒ When the flow mode is Sat_Steam(P), that means saturated steam pressure compensation, the temperature value will display as "----", which means the acquisition of temperature sensor is not activated.
- ☒ When the flow mode is Sat_Steam(T), that means saturated steam temperature compensation, the pressure value will display as "----", which means the acquisition of pressure sensor is not activated.

You can press KEY-M to change the third line display variables. Use indicator to distinguish between different display variables shows in the second line.

Indicator	F:	Den:	P:	T:	Curr:	Per:	P= T=
variable	Frequency	Density	Pressure	Temperature	Loop current	Percentage	Pressure and temperature

3.2 Two-line display mode

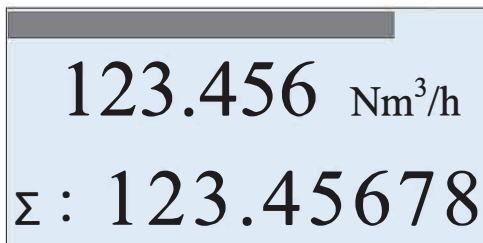

Displays the current percentage in progress bar

First line display instant Instantaneous flow.

The second line display totalized flow.

4 Production Process Using HART-Config Tool

Connect the flow meter as shown in Figure 4-1.

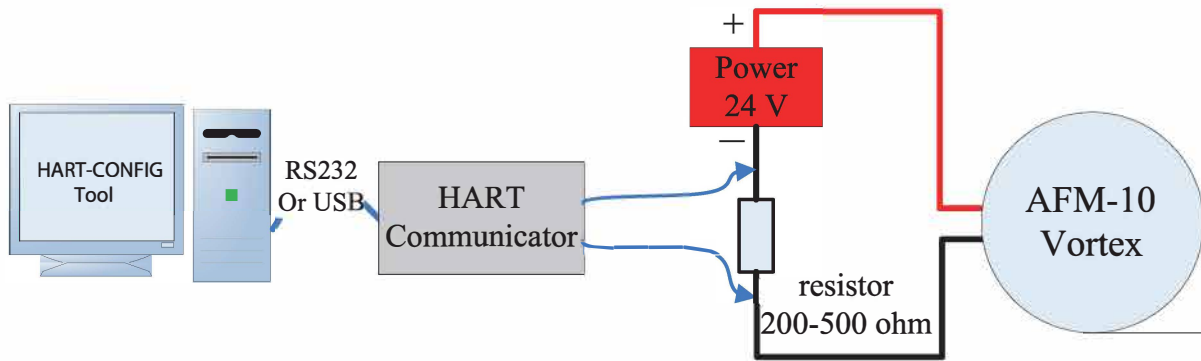
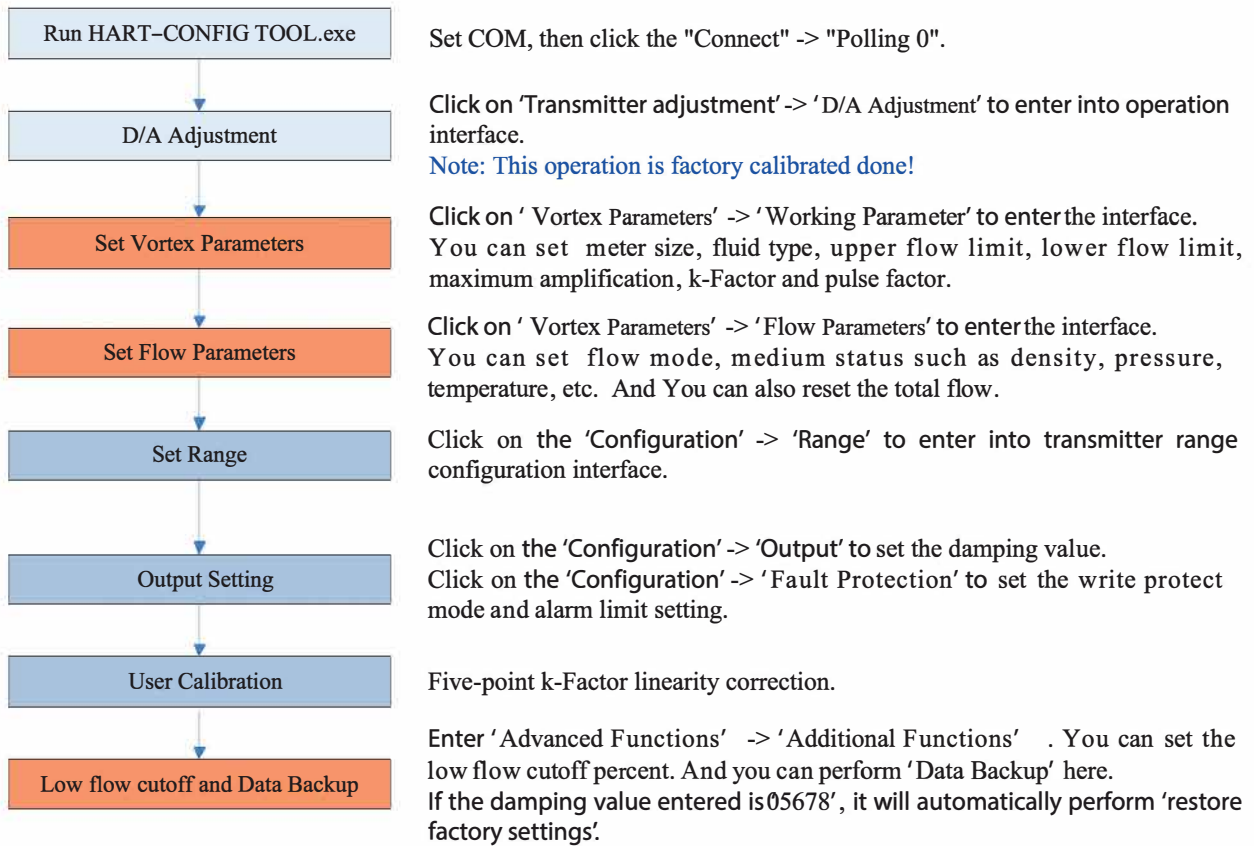

Figure 4-1 HART communication connection diagram

Run the HART-CONFIG TOOL software, and follow these steps to complete the production process of vortex flowmeters.



Note : This color means that these items must be done. This color means that these items must be done, and easily forgotten or incorrectly set.

5 Production Process via Local Adjustment

We recommend the following steps to set parameters.

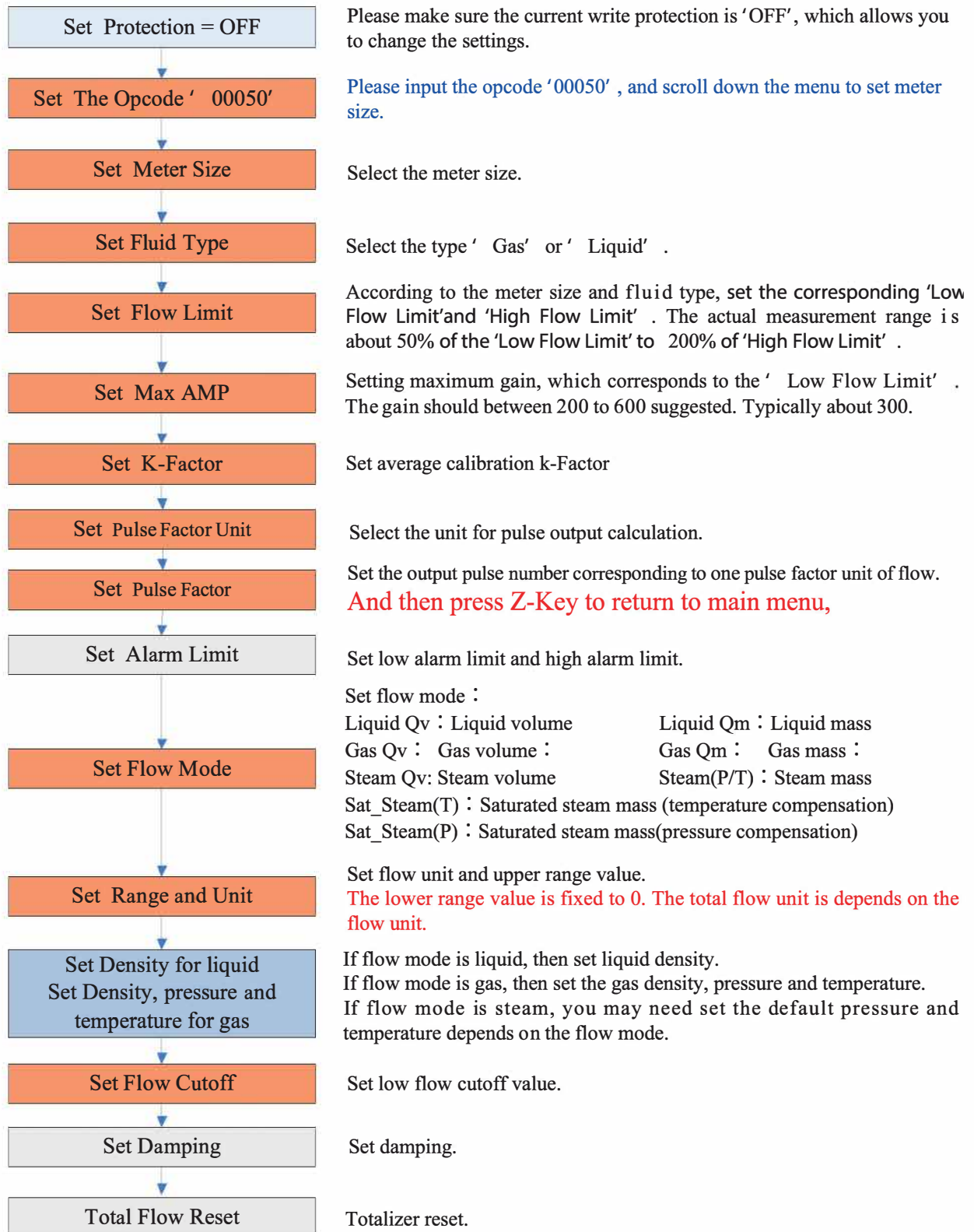

Note :

This color means that these items must be done. This color means that these items must be done, and easily forgotten or incorrectly set.

6 Data Entry

6.1 Basic Function of Keys

Data is entered using the 3 keys M, S and Z on the display.

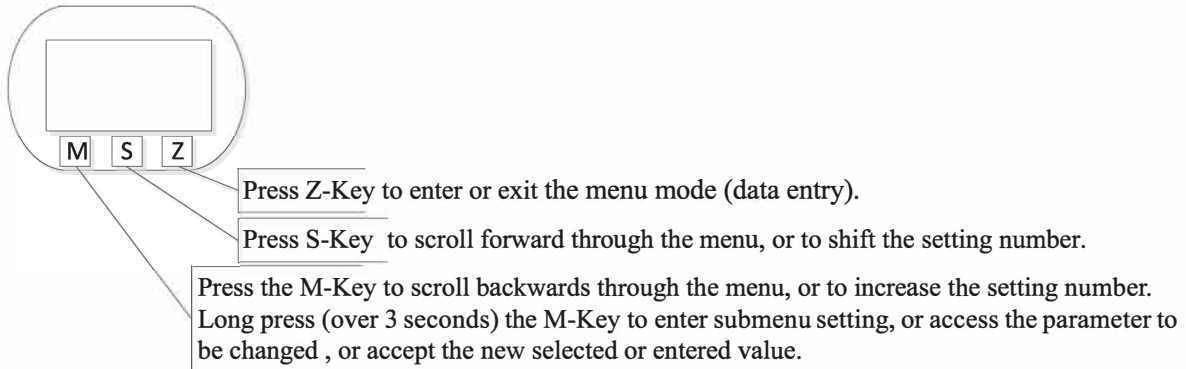

6.2 Enter or Exit Menu Mode

6.2.1 Enter Menu Mode

In the operating mode, press the "Z" key to enter the menu mode (data entry).

6.2.2 Exit Menu Mode

In the menu mode, press the "Z" key to back to the operating mode.

6.3 Data Entry Method

Setting parameters include "select" and "data input" methods.

6.3.1 Select Method

- ☒ Long press M-Key to enter setting, and the menu options will start flashing.
- ☒ Short press M-Key or S-Key to scroll backwards or forwards the menu.
- ☒ Long press M-Key to save (access) the parameter.

6.3.2 Data Input Method

- ☒ Long press the M key, that means press the M button for 3 seconds and then release it to enter the setting. In this state, the underline is on the second line, indicating that the parameters can be modified;
- ☒ Short press the M-Key to switch the sign.
- ☒ Press the S-Key to shift the setting number. Press M-Key to increase the setting number.
- ☒ Press the S-Key to shift the setting number again. All bits can be set according to the same operation.
- ☒ Long press M-Key to save (access) the parameter. Or press Z-Key to give up and exit settings.

For example, the original range 100% is 200 and the range 100% needs to be changed to 400.

<ul style="list-style-type: none"> ☒ Press the Z-key to enter the menu mode. ☒ Press M-Key or S-Key to scroll backwards or forwards the menu until to set the range limit menu. 	Setting the upper range value menu <div style="border: 1px solid black; padding: 5px; text-align: center;"> Range 100% 200.000 </div>
<ul style="list-style-type: none"> ☒ Long press the M key, that means press the M button for 3 seconds and then release it to enter the setting. In this state, the underline is on the second line, indicating that the parameters can be modified; 	Enter setting menu <div style="border: 1px solid black; padding: 5px; text-align: center;"> Range 100% <u>200.000</u> </div>
<ul style="list-style-type: none"> ☒ Press the M-Key to switch the sign between "+" and "-". "- "means data is negative (less than 0, vortex flowmeter upper range value must be a positive number). 	Setting sign <div style="border: 1px solid black; padding: 5px; text-align: center;"> Range 100% <u>+200.000</u> </div>
<ul style="list-style-type: none"> ☒ Press the S-Key to shift the setting number. Then press M-Key to increase the setting number. ☒ If the highest bit is set, the number that can be entered is between 0 and 9; if it is other bits, the decimal point can also be selected. 	Setting sign <div style="border: 1px solid black; padding: 5px; text-align: center;"> Range 100% <u>+400.000</u> </div>
<ul style="list-style-type: none"> ☒ Long press M-Key to save (access) the parameter. ☒ Press Z-Key to give up and exit settings. Return to the previous menu or return to the operating mode. 	

6.4 Local Configuration Function

6.4.1 Basic Function (No Password)

Menu	Setting method	Notes
Contrast	Select	1~5
Protection	Select	ON / OFF
Min Alarm(%)	Data Input	Set low alarm value. Unit: %
Max Alarm(%)	Data Input	Set high alarm value. Unit: %
MeterSize	Read Only	View meter size setting.
Flow mode	Select	Liquid Qv : Liquid volume Liquid Qm : Liquid mass Gas Qv : Gas volume Gas Qm : Gas mass Steam Qv : Steam volume Steam(P/T) : Steam mass Sat_Steam(T) : Saturated steam mass (temperature compensation)

		Sat_Steam(P) : Saturated steam mass(pressure compensation)
Unit-Qv Unit-Qm	Select	Volume units supported: Nm ³ /h, Nm ³ /m, Nm ³ /s, l/s, l/m, l/h, m ³ /s, m ³ /m, m ³ /h, m ³ /d, Scf/s, Scf/m, Scf/h, cf/s, cf/m, cf/h, USG/s, USG /m, USG /h, UKG/s, UKG /m, UKG /h, bbl/h, bbl/d, Mass units supported : g/s , g/m, g/h, kg/s, kg/m, kg/h, kg/d, t/m, t/h, t/d, lb/h, lb/d Note: Totalizer flow's unit based on the flow unit.
Range 100%	Data Input	Set the Qmax value for selected flow mode (= 20 mA)
Density (kg/ m ³) Density (g/c m ³)	Data Input	Set Gas density (unit: Kg/m ³) Set Liquid density (unit: g/cm ³)
Gauge Pre.(Kpa)	Data Input	Use for gas or steam measure. Unit: kpa.
Temperature (°)	Data Input	Use for gas or steam measure. Unit: ° .
PV Cutoff (%)	Data Input	Range: 0% ~ 20%
Damping	Data Input	Range: 0 ~ 64S
Disp. Point	Select	Set the first line display point, can be 0,1,2, 3.
Display Mode	Select	Set display mode.
Totalizer reset	Select	When Lcd display 'Yes', long press M-Key to reset the totalizer and overflow counter.
Number of totalizer overflows	Read Only	Display of the number of totalizer overflows; 1 overflow = 10,000,000
K-Factor	Read Only	View the k-Factor.

6.4.2 Advanced Function (Password Protection)

Opcode	Data Input	Input ****50, set 51~ 57 menu. Input ****60, set 60 menu. Input ****61, set 62 menu. Input ****62, set 62 menu. Input ****63, set 63 menu. Input ****70, set 70~77 menu. Input ****40, set 40~ 41 menu. Input ****38, set 38~ 39 menu. Input ****11, view 11~ 13 menu.
--------	------------	---

		Input ****111, preset total. Input ****721, set temperature sensor trim data. Input ****741, set pressure sensor trim data.
Signal status [51]	Read Only	LCD display : 450.00 This is the PGA gain. CH2 – A CH2 is signal channel. A means 10, it is signal amplitude, it must be greater than 9.
Meter size [52]	Select	Options : 15mm, 20mm, 25mm, 32mm, 40mm, 50mm, 65mm, 80mm, 100mm, 125mm, 150mm, 200mm, 250mm, 300mm, 350mm, 400mm, 450mm, 500mm, 600mm; Note: 1) LCD display DN15, means meter size is 15mm. 2) If you change the meter size, you must re-set from 53 to 56.
Fluid Type [53]	Select	Options : Gas, or Liquid. Note: If you change the fluid type, you must re-set from 53 to 56.
Low Flow Limit [54]	Data Input	According to the meter size and measuring media, set the corresponding low limit of the flow. The unit of 'Low Flow Limit' is fixed as m^3/h . The actual measurement of the lower limit of about 50% of 'Low Flow Limit'.
High Flow Limit [55]	Data Input	The 'High Flow Limit' defaults to 10 times the 'Low Flow Limit', the actual measurement of the upper limit of 2 times the set value. The unit of 'High Flow Limit' is fixed as m^3/h . When the actual required range ratio exceeds 20: 1, you can manually modify the 'High Flow Limit'.
Max AMP. [56]	Data Input	Between 200 and 600 suggested. Typically about 300.
k-Factor [57]	Data Input	Set average calibration k-Factor
Pulse Factor Unit [58]	Select	Options : m^3 , $N m^3$, t, kg, Scf, cf, USG, UKG, bbl, lb.
Pulse factor [59]	Data Input	Set the number of output pulses corresponding to one 'Pulse Factor Unit'. Note: If you want to output the original pulse, set 'K-factor [57]' and 'Pulse factor [59]' to the same value, and 'Pulse Factor Unit [58]' must set to m^3.
[60] K-Factor Trim Fi K-Factor Trim Yi	Data Input	Five-point K-Factor correction. Where Fi is the reference frequency, Yi is the correction coefficient K. $i=1,2,3,4,5$.
[61]	Data Input	The reference frequency value of the five-point correction

Frequency Factor		<p>is multiplied by the Frequency Factor, and then the new reference frequency value of the correction point is obtained.</p> <p>Normally, this value should be 1.</p> <p>When calibrated with water, for gas measurements, you can set the coefficient so that the five-point correction factor remains in effect.</p>
[62] Channel settings	Select	<p>There are CH_1, CH_2, CH_3 three options.</p> <p>CH_3 gain maximum</p> <p>CH_1 gain minimum</p> <p>Note :</p> <p>CH2 generally used for liquid measurement, which corresponds to the configuration software, select X1 and X2.</p> <p>CH_3 generally used for gas measurement, which corresponds to the configuration software, select X1, X2 and X3.</p>
[63] Work mode settings	Select	<p>There are F_1, F_2, F_3, F_4 four options.</p> <p>F_1: Anti-vibration Mode</p> <p>F_2: Normal Mode</p> <p>F_3: Turbine Mode</p> <p>F_4: Test Mode</p> <p>Note :</p> <p>Generally choose F_2.</p>
[40] Trim 4mA		<p>Steps :</p> <ol style="list-style-type: none"> 1. Long press M-Key, enter trim; 2. Short press M-key to decrease current. Press S-Key to increase current. Stepping is 16 microamperes. 3. Long press M-Key to save new trim value. Or press Z-Key to exit without saving.
[41] Trim 20mA		
[70] Temp. Measure	Select	<p>Temperature acquisition mode setting.</p> <p>Options : Manual, or Auto.</p> <p>Manual: Temperature uses the input reference value.</p> <p>Auto: Temperature is automatic acquisition, should be use external Pt1000 or Pt100.</p>
[71] Pressure Measure	Select	<p>Pressure acquisition mode setting.</p> <p>Options : Manual, or Auto.</p> <p>Manual: Pressure uses the input reference value.</p> <p>Auto: Pressure is automatic acquisition, should be use external silicon pressure sensor.</p>
[72] Temperature low trim	Data Input	<p>Enter the lower calibration resistor value. unit: ohm.</p> <p>Use standard resistance as input.</p>

		For example: 1000 for Pt1000, or 100 for Pt100.
[73] Temperature high trim	Data Input	Enter the high calibration resistor value, unit: ohm. Use standard resistance as input For example:2500 for Pt1000, or 250 for Pt100.
[74] Pressure low trim	Data Input	Enter the calibration reference pressure value, unit is Kpa Apply the standard pressure to the sensor. For example: 0 Kpa
[75] Pressure high trim	Data Input	Enter the calibration reference pressure value, unit is Kpa Apply the standard pressure to the sensor. For example: 1000 Kpa
[76] Pre. Cutoff	Data Input	Set the low pressure cutoff value. Unit is Kpa. If the measured pressure value is less than 'Pre. Cutoff', the pressure will be set to 0kpa.
[77] Set Pre. Bias	Data Input	Set the pressure bias value. Unit is Kpa. Enter the current actual pressure value to achieve bias. The pressure will be set to input value.
[38] Min Pre. (Kpa)	Data Input	This parameter is only used for steam mass measurement. In the steam mass measurement mode, if the pressure is less than the set 'minimum pressure value' when the pressure compensation is activated, the flow will automatically return to zero.
[39] Min Temp. (°C)	Data Input	This parameter is only used for steam mass measurement. In the steam mass measurement mode, if the temperature is less than the set 'minimum temperature value' when the temperature compensation is activated, the flow will automatically return to zero.
[11] Version	Read Only	To view the embedded software version.
[12] Max Frequency	Read Only	The internal conversion frequency value corresponds to the 'High Flow Limit'.
[13] Min Frequency	Read Only	The internal conversion frequency value corresponds to the 'Low Flow Limit'.
[111] Total Preset		Used to directly set the current total flow value.
[721] Temp. Data X0; Temp. Data Y0; Temp. Data X1; Temp. Data Y1;	Data Input	You can directly view and modify the temperature sensor calibration values. Temp. Data X0 and Temp. Data X1 are internal ADC measurements. Temp. Data Y0[73] and Temp. Data Y1[74] are the input calibration value.
[741]	Data Input	You can directly view and modify the pressure sensor

Pre. Data X0; Pre. Data Y0; Pre. Data X1; Pre. Data Y1;		calibration values. Pre. Data X0 and Pre. Data X1 are internal ADC measurements. Pre. Data Y0[75] and Pre. Data Y1[76] are the input calibration value.
--	--	---

Special Note :

Low Flow Limit, High Flow Limit, maximum gain and average calibration K- Factor should be reset, if meter size or fluid type changed. These parameters are very important for vortex flowmeter good working, please carefully set according to the actual application.

6.5 Totalizer Flow Unit Table

Totalizer flow's unit is determined according to the flow unit.

Flow Unit	Totalizer Flow Unit
Nm ³ /h, Nm ³ /m, Nm ³ /s	Nm ³
m ³ /d, m ³ /h, m ³ /m, m ³ /s	m ³
l/h, l/m, l/s	L
Scf/s, Scf/m, Scf/h,	Scf
cf/s, cf/m, cf/h,	cf
USG/s, USG /m, USG /h,	USG
UKG/s, UKG /m, UKG /h,	UKG
bbl/h, bbl/d,	bbl
g/h, g/m, g/s	g
kg/d, kg/h, kg/m, kg/s	kg
t/d, t/h, t/m	t
lb/h, lb/d	lb

7 Parameter Description

7.1 K- Factor

The average k-Factor value shown in the display must be the same as the value on the primary tag on the flowmeter primary.

7.2 Five-point Linearity Correction

The actual k-Factor of vortex flowmeter is different in low flowrates and high flowrates. In order to improve the accuracy of vortex flowmeter, it provides 2 to 5 points k-Factor correction.

For example, for D = 80mm, measuring medium is liquid, the real k-Factor in different flowrates as follows:

<20 Hz	40	80	> 100
2200	2100	2100	2000

Then we can choose 4-points calibrated, set k-Factor 2100. Enter the calibration data as follows:

Frequency	k-Factor coefficient	formula
20	0.954545	2100/2200=0.954545

40	1	2100/2100=1
80	1	2100/2100=1
100	1.05	2100/2000=1.05

7.3 Pulse Factor Description

There are two ways to set the pulse factor via HART-CONFIG Tool.

1. Set the number of pulses output every one unit [58] total flow.
2. Set a pulse corresponds to how many of one unit [58] total flow.

The output pulses are based on the flow value after five-point K-Factor correction. That will get higher accuracy than using the original pulses.

The local adjustment menu [59] is used to set the output pulse number corresponding to 1 unit [58] total flow.

7.4 Output Original Pulses Description

If you need the flowmeter outputs original pulses, follow the following steps:

1. Set the K- Factor and the Pulse Factor equal. That is the value of local adjustment menu 57 and 59 equal. And set the pulse factor unit to m^3 .
2. Cancel the Five-point linearity correction via HART-CONFIG Tool. Or enter the local adjustment menu 60 to set all of correction coefficient K equal 1.0.

Then the flowmeter output pulse frequency equals to the original pulse frequency.

7.5 Temperature and Pressure Compensation

7.5.1 Precondition

The pressure sensor should be bridge type sensors and the temperature sensor should be Pt1000

User input reference pressure should be gauge pressure, and the unit must be kpa. Absolute pressure and gauge pressure relationship: Absolute pressure = gauge pressure + 101.325kPa.

User should input the reference resistor when trim the temperature sensor.

7.5.2 Pressure Sensor Trim

If you want trim the pressure sensor, please check the flow mode and pressure acquisition mode setting.

If you want trim the pressure sensor, please check the flow mode and pressure acquisition mode setting.

Menu	Setting
Flow mode	Set one of the following : (Other modes do not use pressure sensor.) Gas Qv : Gas volume Gas Qm : Gas mass Steam Qv : Steam volume Steam(P/T) : Steam mass Sat_Steam(P) : Saturated steam mass(pressure compensation)
[71] Pressure Measure	Pressure acquisition mode setting Auto: Start automatic measurement of external pressure. External pressure sensor required

It provides two points calibration for the pressure sensor. If use HART-CONFIG Tool, please enter into 'Advanced Features' -> 'Temperature and Pressure Sensors' to trim the sensor.

You can also trim the sensor via local adjustment menu 'Pressure low trim' [74] and 'Pressure high trim

'[75]:

1. Set flow mode and pressure acquisition mode.
2. Apply zero pressure to the sensor, enter into menu 'Pressure low trim '[74], input the reference pressure(gauge pressure, unit kpa) to trim zero.
3. Apply full pressure to the sensor, enter into menu 'Pressure high trim '[75], input the reference pressure(gauge pressure, unit kpa) to trim full.

Note: 'Pressure low trim' and 'Pressure full trim' should be calibrated together to ensure that the measured pressure is correct.

It should be noted that the pressure measurement cycle is approximately 4 seconds. The calibration should be performed after the input pressure has stabilized for more than 10 seconds.

7.5.3 Low pressure cutoff value

If the pressure measurement is close to 0Kpa, but it is not stable, for example, varied between -0.01 and 0.01kPa. You can set 'Low pressure cutoff value'to adjust the pressure measurement to 0Kpa.

If the measured pressure value is less than 'Low pressure cutoff value'it will set to be 0kpa.

7.5.4 Pressure bias settings

If there is a fixed pressure deviation, for example, the actual pressure value is 10 Kpa and the measured pressure value is 9.8 Kpa. You can perform 'Set Pre. Bias [7 7]', and enter 10(Kpa) to remove this error.

Enter the current actual pressure value, to achieve bias.

7.5.5 Temperature Sensor Trim

If you want trim the temperature sensor, please check the flow mode and temperature acquisition mode setting.

Menu	Setting
Flow mode	Set one of the following: (Other modes do not use temperature sensor.) Gas Qv : Gas volume Gas Qm : Gas mass Steam Qv : Steam volume Steam(P/T) : Steam mass Sat_Steam(T) : Saturated steam mass(Temperature compensation)
[70] Temperature Measure	Temperature acquisition mode setting Auto: Start automatic measurement of external temperature. External temperature sensor Pt1000 or Pt100 required

It provides two points calibration for the temperature sensor. We recommend use 1000ohm and 2500ohm, or 100ohm and 2500ohm (for PT100) resistors for trim. If use HART-CONFIG Tool, please enter into 'Advanced Features' -> 'Temperature and Pressure Sensors' to trim the sensor.

You can also trim the sensor via local adjustment menu 'Temperature low trim '[72] and 'Temperature high trim '[73]:

1. Set flow mode and temperature acquisition mode.
2. Apply lower resistor, such as 1000ohm, enter into menu 'Temperature low trim '[72], input the reference resistor value(1000) to trim..
3. Apply higher resistor, such as 2500ohm, enter into menu 'Temperature high trim '[73], input the reference resistor value(2500) to trim.

7.6 Measurement Mode Setup Instructions

7.6.1 Gas Qv

A: Measure Working State Volume

Density: Set to the density at 20 \boxtimes (not used for computing)
 Gauge Pre.(Kpa): **0.0KPa** 'Change does not affect the measurement'
 Gas Tem (\boxtimes): **20 \boxtimes** 'Change does not affect the measurement'

B: Measure Standard State Volume(20 \boxtimes)

Density: Set to the density at 20 \boxtimes (not used for computing)
 Gauge Pre.(Kpa): Input working state pressure (Gauge pressure). If the temperature and pressure compensation circuit board is used and set to Pressure automatic acquisition, use real-time pressure
 Tem (\boxtimes): Input working state temperature. If the temperature and pressure compensation circuit board is used and set to Temperature automatic acquisition, use real-time temperature

7.6.2 Gas Qm

A: Current Actual Density is Known (the state transition factor is 1)

Density: Set to the current actual density.
 Gauge Pre.(Kpa): 0.0KPa (Not allowed to change) 'changes affect the measurement'
 Temperature (\boxtimes): 20 \boxtimes (Not allowed to change) 'changes affect the measurement'

B: Standard State Density is Known (state transition calculation is required)

Density: Set to the standard state density. (0 KPa gauge pressure, 20 ° C)
 Gauge Pre.(Kpa): Input working state pressure. If the temperature and pressure compensation circuit board is used and set to Pressure automatic acquisition, use real-time pressure.
 Temperature (\boxtimes): Input working state temperature. If the temperature and pressure compensation circuit board is used and set to Temperature automatic acquisition, use real-time temperature.

7.6.3 Liquid Qv

Density: Set to 1.0 or the current actual density. (Not used for computing)

7.6.4 Liquid Qm

Density: Set to the current actual density.

7.6.5 Steam Qv

Density: Set to 1.205 or the current actual density. (Not used for computing)
 Gauge Pre.(Kpa): 0.0KPa 'Not used for computing'
 Temperature (\boxtimes): 20 \boxtimes 'Not used for computing'

7.6.6 Steam Mass

A: Steam(P/T): (Temperature and Pressure Compensation)

If the external temperature sensor or pressure sensor fails, calculate the steam density according to the input temperature or pressure

Density: Not used for computing

Gauge Pre.(Kpa): Input working state pressure. If the temperature and pressure compensation circuit board is used and set to Pressure automatic acquisition, use real-time pressure,

Temperature (☒): Input working state temperature. If the temperature and pressure compensation circuit board is used and set to Temperature automatic acquisition, use real-time temperature

B: Sat_Steam(T): Saturated Vapor(Temperature Compensation)

If the external temperature sensor fails or the temperature sensor is not connected, the steam density is calculated according to the input temperature.

Density: Not used for computing.

Gauge Pre.(Kpa): Not used for computing.

Temperature (☒): Input working state temperature. If the temperature and pressure compensation circuit board is used and set to Temperature automatic acquisition, use real-time temperature

C: Sat_Steam(P): Saturated Vapor(Pressure Compensation)

If the external pressure sensor fails or the pressure sensor is not connected, the steam density is calculated according to the input pressure.

Density: Not used for computing.

Gauge Pre.(Kpa): Input working state pressure. If the temperature and pressure compensation circuit board is used and set to Pressure automatic acquisition, use real-time pressure.

Temperature (°C): Not used for computing.

7.6.7 LANGUAGE OPTION

Press one time Z button and the menu will open. You can use Middle button (S) for Slide Right at the menu section, Continue press S button until see code section. When you see code section, hold press M button (left one) a few second and the screen will allow you enter code. Use S button for going right also use M button for increase number's. set there password as 00509. when you set the password ,hold press a few second M button then language setting should open. After see language change section please hold press M button and device will allow to you change language from Turkish to english or opposite , after you're done hold press M button a few second then setting is complete. After language set complete You can use Z button 2 times back to main screen.

7.7 TECHNICAL DRAWING / INSTALLATION INFORMATION / MEASUREMENT INTERVALS

Sandwich Type Connection Dimensions

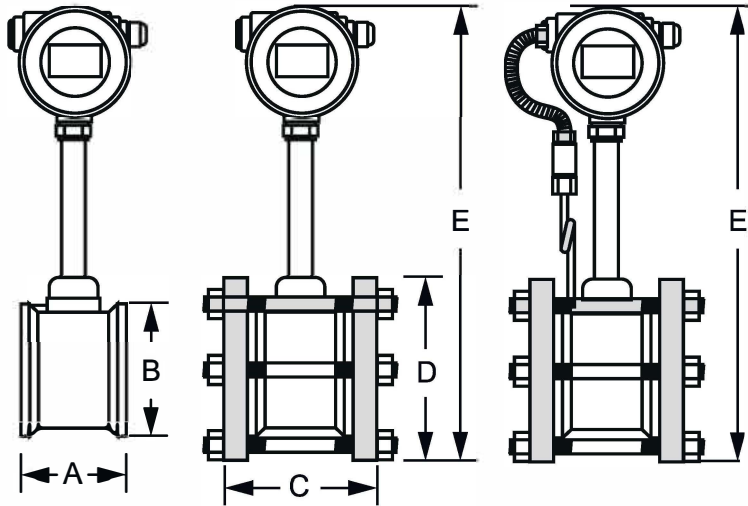

mm	A	B	C	D	E	F
15-20-25-32	68	54	96	100	440	470
40	82	78	110	140	460	490
50	85	87	110	145	490	520
65	84	105	112	165	510	540
80	88	120	116	176	540	570
100	91	140	120	200	560	590
125	92	168	126	230	580	610
150	96	194	130	265	600	630
200	101	248	140	320	630	660
250	114	300	160	370	660	690
300	128	350	170	445	690	720

Flanged Type Connection Dimensions

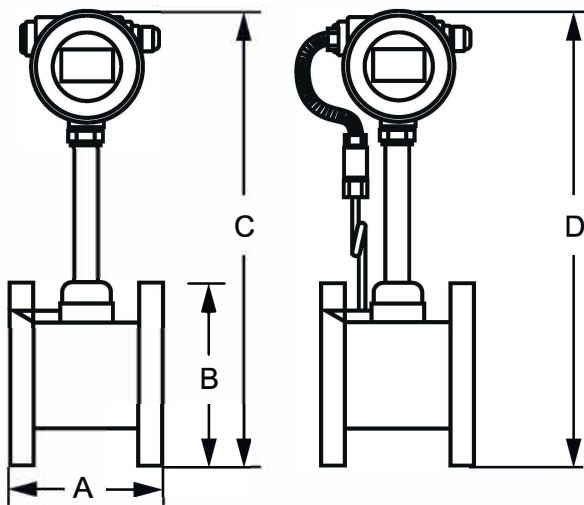

mm	A	B	C	D
15	170	95	430	460
20	170	105	430	460
25	170	115	440	470
32	170	132	450	480
40	160	150	480	510
50	160	160	480	510
65	160	180	530	560
80	180	195	530	560
100	180	215	550	580
125	180	245	560	590
150	180	280	590	620
200	200	340	620	680
250	200	405	710	740
300	350	460	750	780

7.7 TECHNICAL DRAWING / INSTALLATION INFORMATION / MEASUREMENT INTERVALS

For accurate and precise measurements in liquid fluids, prevent the formation of air bubbles in the pipe. Air bubbles in the line cause erroneous measurements.

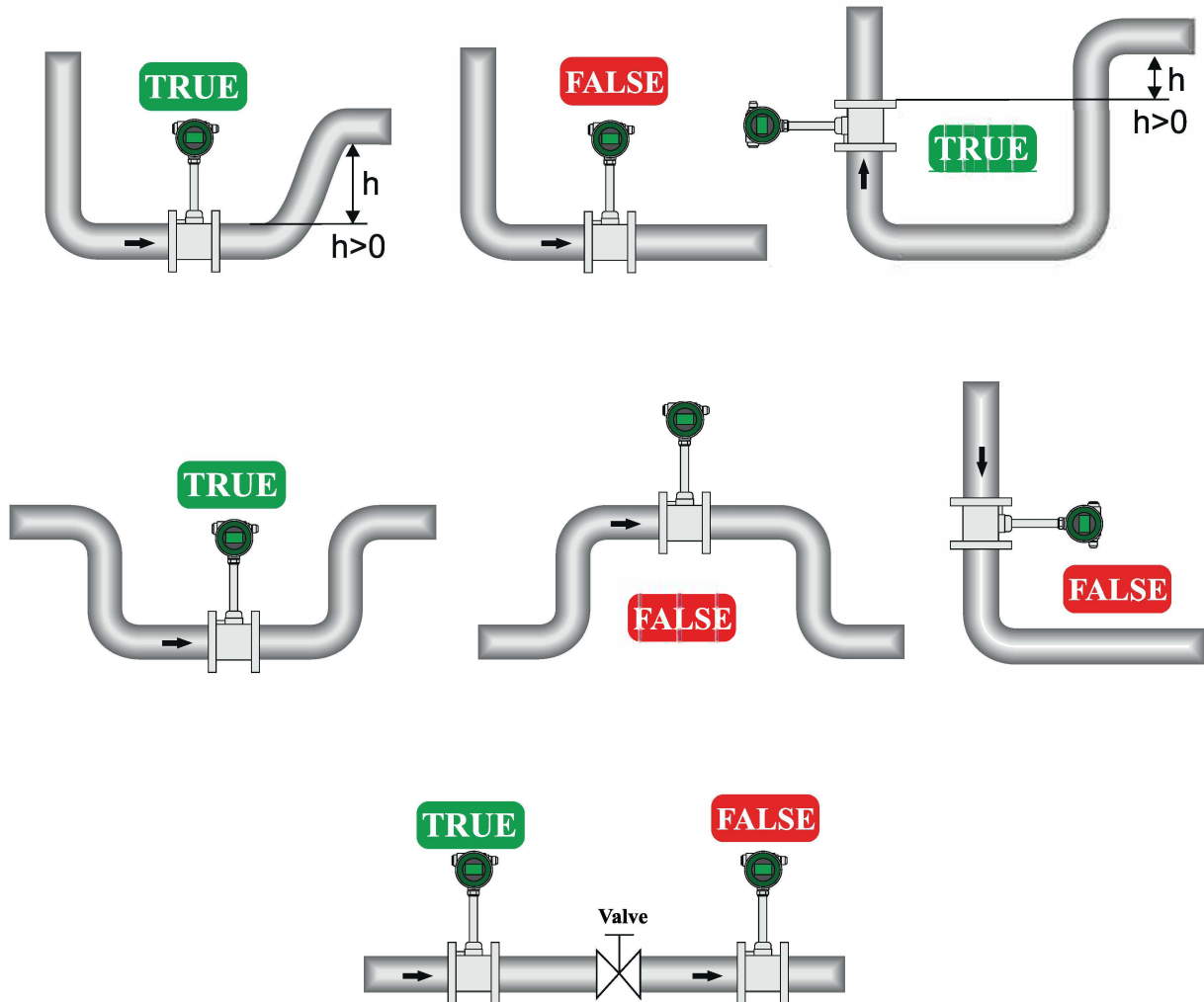

*The installation of the flow meter must be before the valve.

Pipe Connection Type	Straight Distance	
	Login	Exit
Concentric Shrink Pipe	15D	5D
Concentric Expanding Pipe	35D	5D
90° Elbow	20D	5D
90° Double Elbow (Same Plane)	25D	5D
90° Double Elbow (Different Plane)	30D	5D
Valve (Full Open)	20D	5D
Valve (Half Open)	40D	5D

7.7 TECHNICAL DRAWING / INSTALLATION INFORMATION / MEASUREMENT INTERVALS

MEASURABLE FLOW RANGE ACCORDING TO PRODUCT DIAMETER AND FLUID

DN	K-factor	Liquid (m3/h)	Frequency (HZ)	Gas (m3/h)	Frequency (HZ)	Steam (m3/h)	Frequency (HZ)
15	350000	0.5-5	88-580	3-20	240-2350	4-50	260-2000
20	148000	0.6-10	38-422	5-40	210-2132	7-80	210-1900
25	74980.3	1-16	25-336	8-60	190-1140	10-80	210-1680
32	30511	1.8-18	16-264	20-120	150-1100	12-120	156-1080
40	17523.5	2-30	10-200	30-180	140-1040	25-180	126-910
50	9451.2	3-50	8-160	40-350	94-1020	40-260	100-700
65	4113	5-50	6.1-77.1	70-650	80.7-807	35-800	94-940
80	2346	7-100	4.1-82	90-900	55-690	100-800	63-500
100	1153.5	15-180	4.7-69	150-1500	42-536	160-1100	50-350
125	573.1	20-210	3.3-41.6	250-2200	38-416	150-2000	38-475
150	334	30-400	2.8-43	350-3500	33-380	400-3500	38-350
200	141.5	50-700	2-31	600-7000	22-315	580-7000	23-270
250	70.8	70-1000	1.5-25	1000-9000	18-221	960-9600	20-200
300	42.98	100-1800	1.2-24	1500-14000	16-213	1300-13000	16-160

FLOW CHANGE TABLE ACCORDING TO SATURATED STEAM PRESSURE

DN (mm)	Debi	Measurable Flow Values (kg/h)								
		1 Bar	2 Bar	4 Bar	6 Bar	8 Bar	10 Bar	15 Bar	20 Bar	25 Bar
15	Min	2,2	3,2	5,1	7,1	8,9	10,8	15,5	20,2	25,0
	Max	54,5	79,6	128,4	176,3	223,7	270,8	388,2	505,9	624,5
20	Min	3,8	5,6	9,0	12,3	15,7	19,0	27,2	35,4	43,7
	Max	95,4	139,2	224,6	308,5	391,4	473,9	679,3	885,3	1092,9
25	Min	6,1	8,9	14,4	19,8	25,2	30,5	43,7	56,9	70,3
	Max	153,4	223,7	361,0	495,7	629,1	761,6	1091,8	1422,8	1756,5
32	Min	10,2	14,9	24,1	33,0	41,9	50,8	72,8	94,9	117,1
	Max	255,6	372,9	601,7	826,2	1048,4	1269,3	1819,7	2371,4	2927,5
40	Min	15,7	22,9	36,9	50,7	64,3	77,9	111,6	145,4	179,6
	Max	392,0	571,8	922,6	1266,9	1607,6	1946,3	2790,1	3636,1	4488,8
50	Min	23,9	34,8	56,2	77,1	97,9	118,5	169,8	221,3	273,2
	Max	596,5	870,1	1404,0	1927,8	2446,3	2961,8	4245,9	5533,2	6830,7
65	Min	49,1	71,6	115,5	158,6	201,3	243,7	349,4	455,3	562,1
	Max	1227,0	1789,9	2888,2	3965,8	5032,5	6092,8	8734,4	11382,6	14051,8
80	Min	61,4	89,5	144,4	198,3	251,6	304,6	436,7	569,1	702,6
	Max	1533,8	2237,4	3610,3	4957,3	6290,6	7616,0	10918,0	14228,2	17564,7
100	Min	95,4	139,2	224,6	308,5	391,4	473,9	679,3	885,3	1092,9
	Max	2385,8	3480,4	5616,0	7711,3	9785,3	11847,1	16983,5	22132,8	27322,9
125	Min	150,0	218,8	353,0	484,7	615,1	744,7	1067,5	1391,2	1717,4
	Max	3749,2	5469,3	8825,2	12117,8	15376,9	18616,8	26688,4	34780,1	42935,9
150	Min	204,5	298,3	481,4	661,0	838,7	1015,5	1455,7	1897,1	2342,0
	Max	5112,5	7458,1	12034,3	16524,2	20968,5	25386,6	36393,2	47427,4	58549,0
200	Min	374,9	546,9	882,5	1211,8	1537,7	1861,7	2668,8	3478,0	4293,6
	Max	9373,0	13673,2	22062,9	30294,4	38442,3	46542,0	66720,9	86950,3	107339,9
250	Min	599,9	875,1	1412,0	1938,8	2460,3	2978,7	4270,1	5564,8	6869,8
	Max	14996,8	21877,1	35300,6	48471,0	61507,7	74467,3	106753,4	139120,4	171743,8
300	Min	852,1	1243,0	2005,7	2754,0	3494,8	4231,1	6065,5	7904,6	9758,2
	Max	21302,2	31075,4	50142,9	68850,9	87368,9	105777,4	151638,4	197614,2	243954,2